

100Gbps QSFP28 CWDM4 2Km with FEC

SLQS28-100G-CWDM4



Overview

This product is a transceiver module designed for 2km optical communication applications. The design is compliant to 100GBASE CWDM4 MSA standard. The module converts 4 input channels (CH) of 25Gb/s electrical data to 4 CWDM optical signals, and multiplexes them into a single channel for 100Gb/s optical transmission. Reversely, on the receiver side, the module optically de-multiplexes a 100Gb/s input into 4 CWDM channels signals, and converts them to 4 channel output electrical data.

The central wavelengths of the 4 CWDM channels are 1271, 1291, 1311 and 1331 nm as members of the CWDM wavelength grid defined in ITU-T G.694.2. It contains a duplex LC connector for the optical interface and a 38-pin connector for the electrical interface. To minimize the optical dispersion in the long-haul system, single-mode

fiber (SMF) has to be applied in this module. Host FEC is required to support up to 2km fiber transmission.

The product is designed with form factor, optical/electrical connection and digital diagnostic interface according to the QSFP28 Multi-Source Agreement (MSA). It has been designed to meet the harshest external operating conditions including temperature, humidity and EMI interference.

Features

- ◆ QSFP28 MSA compliant
- ◆ 4 CWDM lanes MUX/DEMUX design
- ◆ Supports 103.1Gb/s aggregate bit rate
- ◆ 100G CWDM4 MSA Technical Spec Rev1.1
- ◆ Up to 2km transmission on single mode fiber (SMF) with FEC
- ◆ Operating case temperature: 0 to 70oC
- ◆ 4x25G electrical interface (OIF CEI-28G-VSR)
- ◆ Maximum power consumption 3.5W
- ◆ LC duplex connector
- ◆ RoHS compliant

Applications

- ◆ Data Center Interconnect
- ◆ 100G Ethernet
- ◆ Infiniband QDR and DDR interconnects
- ◆ Enterprise networking

Ordering Information

Part Number	Product Description
SLQS28-100G-CWDM4	100G QSFP28 CWDM4 2Km with FEC

Module Block Diagram

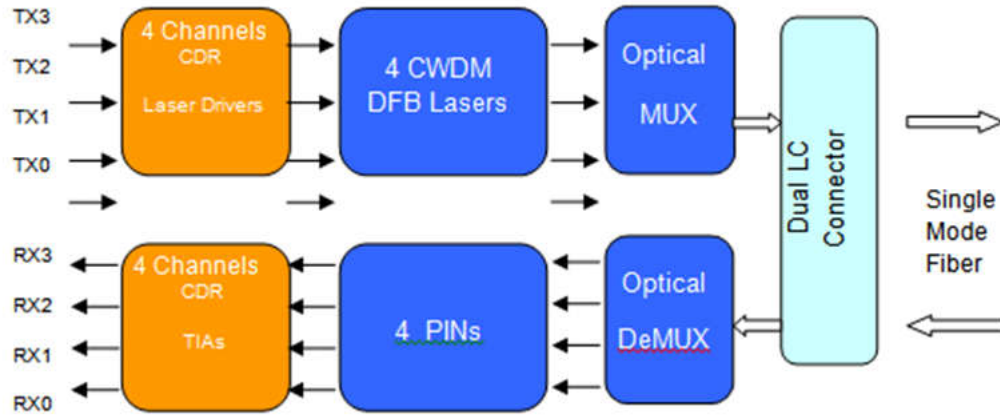

Figure1. Module Block Diagram

Absolute Maximum Ratings

It has to be noted that operation in excess of any individual absolute maximum ratings might cause permanent damage to this module.

Parameter	Symbol	Min	Max	Unit
Supply Voltage	V _{CC}	-0.5	3.6	V
Storage Temperature	T _{st}	-40	85	°C
Case Operating Temperature	T _{op}	0	70	°C
Relative Humidity (non-condensing)	RH	0	85	%
Damage Threshold, each Lane	THd	-3.5		dBm

Recommended Operating Conditions and Power Supply Requirements

Parameter	Symbol	Min	Typical	Max	Unit
Supply Voltage	V _{CC}	3.135	3.3	3.465	V
Operating Case temperature	T _{op}	0		70	°C
Data Rate Per Lane			25.78125		Gbps
Data Rate Accuracy		-100		100	ppm
Control Input Voltage High		2		V _{CC}	V
Control Input Voltage Low		0		0.8	V
Link Distance with G.652	D	0.002		2	Km

Electrical Specifications

The following electrical characteristics are defined over the Recommended Operating Environment unless otherwise specified.

Parameter	Test Point	Min	Typical	Max	Unit	Notes
Power Consumption				3.5	W	
Supply Current	Icc			1.06	A	
Transmitter (Each Lane)						
Overload Differential Voltage pk-pk	TP1a	900			mV	
Common Mode Voltage (Vcm)	TP1	-350		2850	mV	1
Differential Termination Resistance Mismatch	TP1			10	%	2
Differential Return Loss (SDD11)	TP1			See CEI-28G-VSR equation 13-19	dB	
Common Mode to Differential conversion and Differential to Common Mode conversion (SDC11, SCD11)	TP1			See CEI-28G-VSR equation 13-20	dB	
Stressed Input Test	TP1a	See CEI-28G-VSR Section 13.3.11.2.1				
Receiver (Each Lane)						
Differential Voltage, pk-pk	TP4			900	mV	
Common Mode Voltage (Vcm)	TP4	-350		2850	mV	1
Common Mode Noise, RMS	TP4			17.5	mV	
Differential Termination Resistance Mismatch	TP4			10	%	2
Differential Return Loss (SDD22)	TP4			See CEI-28G-VSR equation 13-19	dB	
Common Mode to Differential conversion and Differential to Common Mode conversion (SDC22, SCD22)	TP4			See CEI-28G-VSR equation 13-21	dB	
Common Mode Return Loss (SCC22)	TP4			-2	dB	3
Transition Time, 20 to 80%	TP4	9.5			ps	
Vertical Eye Closure (VEC)	TP4			5.5	dB	
Eye Width at 10 ⁻¹⁵ probability (EW15)	TP4	0.57			UI	
Eye Height at 10 ⁻¹⁵ probability (EH15)	TP4	228			mV	

Notes:

1. Vcm is generated by the host. Specification includes effects of ground offset voltage.
2. At 1MHz
3. From 250MHz to 30GHz.

Datasheet

Optical Characteristics

Parameter	Symbol	Min	Typical	Max	Unit	Notes
Lane Wavelength	L0	1264.5	1271	1277.5	nm	
	L1	1284.5	1291	1297.5	nm	
	L2	1304.5	1311	1317.5	nm	
	L3	1324.5	1331	1337.5	nm	
Transmitter						
SMSR	SMSR	30			dB	
Total Average Launch Power	P_T			8.5	dBm	
Average Launch Power, each Lane	P_{AVG}	-6.5		2.5	dBm	
OMA, each Lane	P_{OMA}	-4		2.5	dBm	1
Difference in Launch Power between any Two Lanes (OMA)	$P_{Tx,diff}$			3.6	dB	
Launch Power in OMA minus Transmitter and Dispersion Penalty (TDP), each Lane		-5			dBm	
TDP, each Lane	TDP			3.0	dB	
Extinction Ratio	ER	3.5			dB	
Relative Intensity Noise	RIN			-130	dB/Hz	12dB reflection
Optical Return Loss Tolerance	TOL			20	dB	
Transmitter Reflectance	R_T			-12	dB	
Eye Mask {X1, X2, X3, Y1, Y2, Y3}		{0.31, 0.4, 0.45, 0.34, 0.38, 0.4}				2
Average Launch Power OFF Transmitter, each Lane	P_{OFF}			-30	dBm	
Receiver						
Damage Threshold, each Lane	THd	3.5			dBm	3
Total Average Receive Power				8.5	dBm	
Average Receive Power, each Lane		-11.5		2.5	dBm	
Receive Power (OMA), each Lane				2.5	dBm	
Receiver Sensitivity (OMA), each Lane	SEN			-10	dBm	
Stressed Receiver Sensitivity (OMA), each Lane				-7.3	dBm	4
Receiver reflectance				-26	dB	
LOS Assert	LOS_A	-30			dBm	
LOS De-Assert	LOS_D			-12	dBm	
LOS Hysteresis	LOS_H	0.5			dB	
Receiver Electrical 3 dB upper Cutoff Frequency, each Lane	F_c			31	GHz	

Datasheet

Conditions of Stress Receiver Sensitivity Test (Note 5)

Vertical Eye Closure Penalty, each Lane		1.9	dB
Stressed Eye J2 Jitter, each Lane		0.33	UI
Stressed Eye J9 Jitter, each Lane		0.48	UI
SRS eye mask definition { X1, X2, X3, Y1, Y2, Y3}	{0.39, 0.5, 0.5, 0.39, 0.39, 0.4}		

Notes:

1. Even if the TDP < 1.0 dB, the OMA min must exceed the minimum value specified here.
2. Hit ratio 5×10^{-5}
3. The receiver shall be able to tolerate, without damage, continuous exposure to a modulated optical input signal having this power level on one lane. The receiver does not have to operate correctly at this input power.
4. Measured with conformance test signal at receiver input for BER = 5×10^{-5} .
5. Vertical eye closure penalty and stressed eye jitter are test conditions for measuring stressed receiver sensitivity. They are not characteristics of the receiver.

Pin Assignment

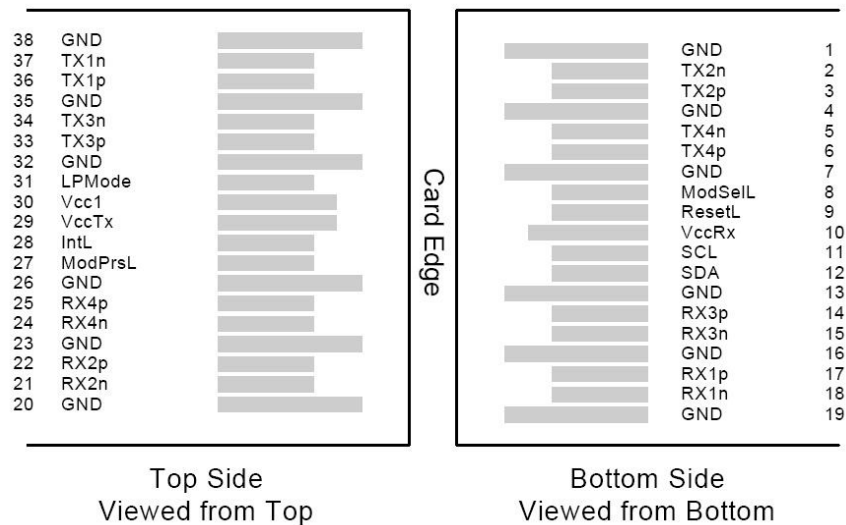

Figure2. Electrical Pin-out Details

Pin Descriptions

Pin	Logic	Symbol	Name/Description	Notes
1		GND	Ground	1
2	CML-I	Tx2n	Transmitter Inverted Data Input	
3	CML-I	Tx2p	Transmitter Non-Inverted Data output	
4		GND	Ground	1
5	CML-I	Tx4n	Transmitter Inverted Data Input	
6	CML-I	Tx4p	Transmitter Non-Inverted Data output	
7		GND	Ground	1
8	LVTLL-I	ModSelL	Module Select	

Datasheet

9	LVTL-I	ResetL	Module Reset	
10		VccRx	+3.3V Power Supply Receiver	2
11	LVCMS-I/O	SCL	2-Wire Serial Interface Clock	
12	LVCMS-I/O	SDA	2-Wire Serial Interface Data	
13		GND	Ground	
14	CML-O	Rx3p	Receiver Non-Inverted Data Output	
15	CML-O	Rx3n	Receiver Inverted Data Output	
16		GND	Ground	1
17	CML-O	Rx1p	Receiver Non-Inverted Data Output	
18	CML-O	Rx1n	Receiver Inverted Data Output	
19		GND	Ground	1
20		GND	Ground	1
21	CML-O	Rx2n	Receiver Inverted Data Output	
22	CML-O	Rx2p	Receiver Non-Inverted Data Output	
23		GND	Ground	1
24	CML-O	Rx4n	Receiver Inverted Data Output	1
25	CML-O	Rx4p	Receiver Non-Inverted Data Output	
26		GND	Ground	1
27	LVTTL-O	ModPrsL	Module Present	
28	LVTTL-O	IntL	Interrupt	
29		VccTx	+3.3 V Power Supply transmitter	2
30		Vcc1	+3.3 V Power Supply	2
31	LVTTL-I	LPMODE	Low Power Mode	
32		GND	Ground	1
33	CML-I	Tx3p	Transmitter Non-Inverted Data Input	
34	CML-I	Tx3n	Transmitter Inverted Data Output	
35		GND	Ground	1
36	CML-I	Tx1p	Transmitter Non-Inverted Data Input	
37	CML-I	Tx1n	Transmitter Inverted Data Output	
38		GND	Ground	1

Notes:

1. GND is the symbol for signal and supply power) common for the QSFP28 module. All are common within the QSFP28 module and all module voltages are referenced to this potential unless otherwise noted. Connect these directly to the host board signal common ground plane.
2. VccRx, Vcc1 and VccTx are the receiving and transmission power suppliers and shall be applied concurrently. Recommended host board power supply filtering is shown in Figure 4 below. Vcc Rx, Vcc1 and Vcc Tx may be internally connected within the module in any combination. The connector pins are each rated for a maximum current of 1000mA.

Recommended Power Supply Filter

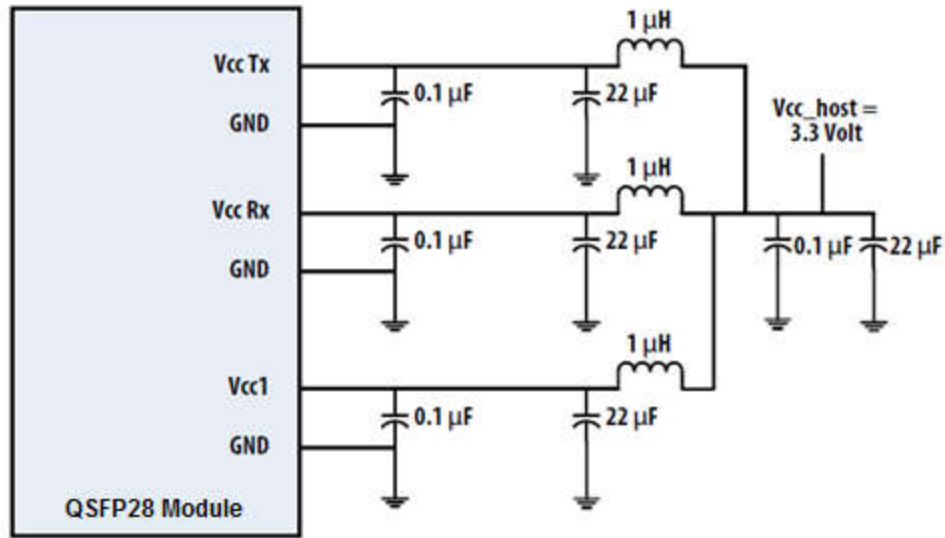

Figure3. Recommended Power Supply Filter

Digital Diagnostic Functions

The following digital diagnostic characteristics are defined over the Recommended Operating Environment unless otherwise specified. It is compliant to SFF-8436.

Parameter	Symbol	Min	Max	Unit	Notes
Temperature monitor absolute error	DMI_Temp	-3	3	°C	1
Supply voltage monitor absolute error	DMI_VCC	-0.1	0.1	V	2
Channel RX power monitor absolute error	DMI_RX_Ch	-2	2	dB	3
Channel Bias current monitor	DMI_Ibias_Ch	-10%	10%	mA	
Channel TX power monitor absolute error	DMI_TX_Ch	-2	2	dB	3

Notes:

1. Over operating temperature range
2. Over full operating range
3. Due to measurement accuracy of different single mode fibers, there could be an additional +/- 1 dB fluctuation, or a +/- 3 dB total accuracy.

Mechanical Dimensions

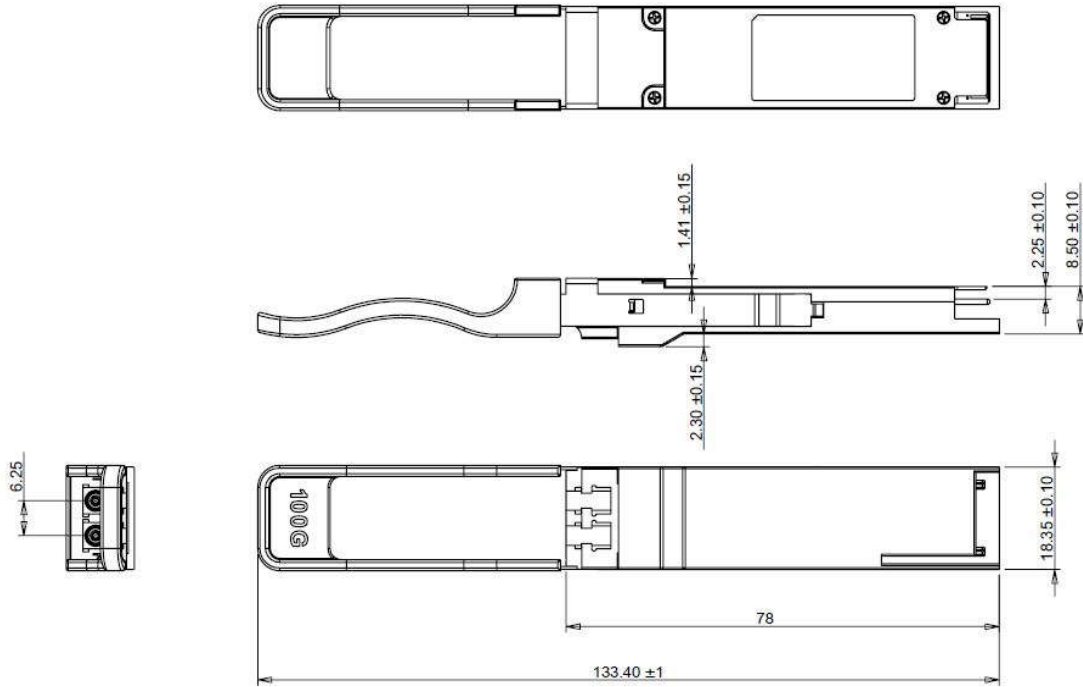

Figure4. Mechanical Specifications

ESD

This transceiver is specified as ESD threshold 1kV for high speed data pins and 2kV for all other electrical input pins, tested per MIL-STD-883, Method 3015.4 /JESD22-A114-A (HBM). However, normal ESD precautions are still required during the handling of this module. This transceiver is shipped in ESD protective packaging. It should be removed from the packaging and handled only in an ESD protected environment.

Laser Safety

This is a Class 1 Laser Product according to EN 60825-1:2014. This product complies with 21 CFR 1040.10 and 1040.11 except for deviations pursuant to Laser Notice No. 50, dated (June 24, 2007).

Caution: Use of controls or adjustments or performance of procedures other than those specified herein may result in hazardous radiation exposure.

Shenzhen Sourcelight Technology Co., Ltd

Sourcelight Technology reserves the right to make changes to or discontinue any optical link product or service identified in this document without notice in order to improve design and/or performance. If you have any question regarding this specification sheet, please contact our sales representative or send email to sales@sourcelight.com.cn