

25G SFP28 1310nm 10km LR

SLSS-2531-LR



Overview

SLSS-2531-LR 25G SFP28 transceivers, this 1310 nm DFB 25 Gigabit SFP28 transceiver is designed to transmit and receive optical data over single mode optical fiber for link length 10km.

The SFP28 LR module electrical interface is compliant to SFI electrical specifications. The transmitter input and receiver output impedance is 100 Ohms differential. Data lines are internally AC coupled. The module provides differential termination and reduce differential to common mode conversion for quality signal termination and low EMI. SFI typically operates over 200 mm of improved FR4 material or up to about 150mm of standard FR4 with one connector.

Ordering Information

Part Number	Product Description
SLSS-2531-LR	SFP28 25Gbps, 1310nm, SMF 10km, 0°C ~ +70°C

Features

- ◆ 25Gb/s serial optical interface
- ◆ 1310nm DFB transmitter, PIN photo-detector
- ◆ 2-wire interface for management specifications compliant with SFF 8472 digital diagnostic monitoring interface for optical transceivers
- ◆ Operating case temperature: 0°C to 70°C
- ◆ Advanced firmware allow customer system encryption information to be stored in transceiver
- ◆ Cost effective SFP28 solution, enables higher port densities and greater bandwidth
- ◆ RoHS compliant

Applications

- ◆ High-speed storage area networks
- ◆ Computer cluster cross-connect
- ◆ Custom high-speed data pipes

Absolute Maximum Rating

Parameters	Symbol	Min.	Max.	Unit
Power Supply Voltage	VCC	0	3.6	V
Storage Temperature	Tc	-40	85	°C
Operating Case Temperature	Tc	0	70	°C
Relative Humidity	RH	5	95	%
Damage Threshold	Pmax	5		dBm

Recommended Operating Condition

Parameter	Symbol	Min.	Typical	Max	Unit
Power Supply Voltage	VCC	3.135	3.3	3.465	V
Power Supply Current	Icc			450	mA
Operating Case Temperature	TC	0	25	70	°C

Transceiver Optical Characteristics

Parameter	Symbol	Minimum	Typical	Maximum	Unit	Notes
Transmitter						
Center Wavelength	λ_t	1290		1330	nm	
Side Mode Suppression Ratio	SMSR	30			dB	
Average Optical Power	Pavg	-8.4	-	3	dBm	1
Laser Off Power	Poff	-	-	-30	dBm	
Extinction Ratio	ER	3.5	-	-	dB	
Transmitter Dispersion Penalty	TDP	-	-	-	dB	TBD
Relative Intensity Noise	Rin	-	-	-	dB/Hz	12dB reflection
Optical Return Loss Tolerance		-	-	-	dB	TBD
Receiver						
Center Wavelength	λ_r	1260		1360	nm	
Receiver Sensitivity in average power	Psens	-	-	-10.4	dBm	1
Receiver Sensitivity in OMA	Psens	-	-	-8.6	dBm	2
Stressed Sensitivity (OMA)		-	-	-6.8	dBm	2
Stressed eye jitter		-			UIp-p	TBD
Receive electrical 3dB upper cutoff frequency					GHz	TBD
LOS Assert	LOSA	-	-	-	dBm	TBD
LOS Deassert	LOSD	-	-	-	dBm	TBD
LOS Hysteresis	LOSH	-	-	-	dB	TBD
Overload	Pin	-	-	3.5	dBm	1

Datasheet

Receiver power damage				5	dBm	
Receiver Reflectance		-	-	-12	dB	

Notes:

1. Average optical power shall be measured using the methods specified in TIA/EIA-455-95.
2. Receiver sensitivity is informative. Stressed receiver sensitivity shall be measured with conformance test signal for BER = 1×10^{-12} .
3. Vertical eye closure penalty and stressed eye jitter are the test conditions for measuring stressed receiver sensitivity. They are not the required characteristic of the receiver.

Transmitter Electrical Characteristics

Parameter	Symbol	Minimum	Typical	Maximum	Unit	Notes
Data Rate		-	25.78	-	Gbps	
Power Consumption		-	1200	1500	mW	
Single Ended Output Voltage Tolerance		-0.3	-	4	V	
C common mode voltage tolerance		15	-	-	mV	
Tx Input Diff Voltage	VI	180		700	mV	
Tx Fault	VoL	-0.3		0.4	V	At 0.7mA
Data Dependent Input Jitter	DDJ			0.1	UI	
Data Input Total Jitter	TJ	-	-	-	UI	TBD

Receiver Electrical Characteristics

Parameter	Symbol	Minimum	Typical	Maximum	Unit	Notes
Single Ended Output Voltage Tolerance		-0.3	-	4	V	
Rx Output Diff Voltage	Vo	300		900	mV	
Rx Output Rise and Fall Time	Tr/Tf	9.5			ps	20% to 80%
Total Jitter	TJ	-	-	-	UI	TBD
Deterministic Jitter	DJ	-	-	-	UI	TBD

Pin Definition

Pin	Symbol	Name/Description	Note
1	VEET	Transmitter Ground	1
2	TX_Fault	Transmitter Fault (LVTTTL-O) - High indicates a fault condition	
3	TX_Disable	Transmitter Disable (LVTTTL-I) – High or open disables the transmitter	
4	SDA	Two wire serial interface Data Line (LVCMOS-I/O) (MOD-DEF2)	2
5	SCL	Two wire serial interface Clock Line (LVCMOS-I/O) (MOD-DEF1)	2
6	MOD_ABS	Module Absent (Output), connected to VeeT or VeeR in the module	
7	RS0	Rate Select 0 – Not used, Presents high input impedance	
8	RX_LOS	Receiver Loss of Signal (LVTTTL-O)	

Datasheet

9	RS1	Rate Select 1 – Not used, Presents high input impedance	
10	VeeR	Receiver Ground	1
11	VeeR	Receiver Ground	1
12	RD-	Inverse Received Data out (CML-O), AC Coupled	
13	RD+	Received Data out (CML-O), AC Coupled	
14	VeeR	Receiver Ground	1
15	VccR	Receiver Power - +3.3V	
16	VccT	Transmitter Power - +3.3 V	
17	VEET	Transmitter Ground	1
18	TD+	Transmitter Data In (CML-I), AC Coupled	
19	TD-	Inverse Transmitter Data In (CML-I), AC Coupled	
20	VEET	Transmitter Ground	1

Notes:

1. Module ground pins GND are isolated from the module case.
2. Shall be pulled up with 4.7K-10Kohms to a voltage between 3.15V and 3.45V on the host board.

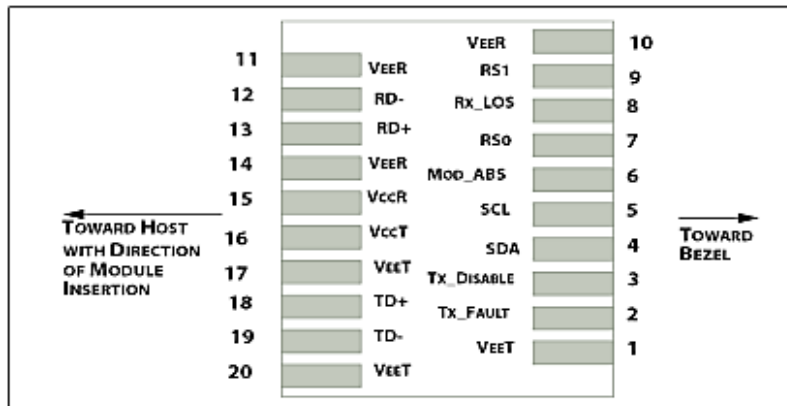

Figure 1: Interface to Host PCB

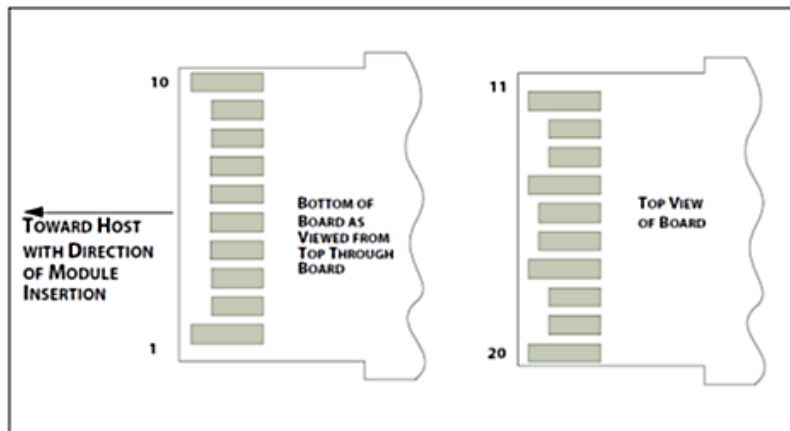

Figure 2: Module Contact Assignment

Digital Diagnostic Functions

The following digital diagnostic characteristics are defined over the Recommended Operating Environment unless otherwise specified. It is compliant to SFF8472 Rev10.2 with internal calibration mode. For external calibration mode please contact our sales staff.

Parameter	Symbol	Min.	Max	Unit	Notes
Temperature monitor absolute error	DMI_Temp	-3	3	degC	Over operating temp
Laser power monitor absolute error	DMI_TX	-3	3	dB	
RX power monitor absolute error	DMI_RX	-3	3	dB	-1dBm to -15dBm range
Supply voltage monitor absolute error	DMI_VCC	-0.1	0.1	V	Full operating range
Bias current monitor	DMI_Ibias	-10%	10%	mA	

Transceiver Block Diagram

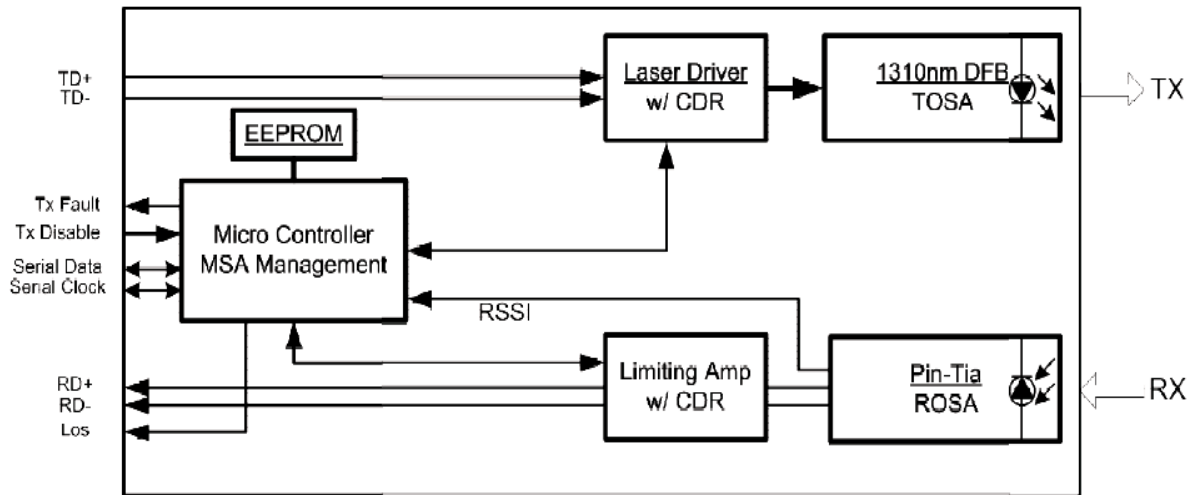

Figure 3: Transceiver Block Diagram

Mechanical Specifications

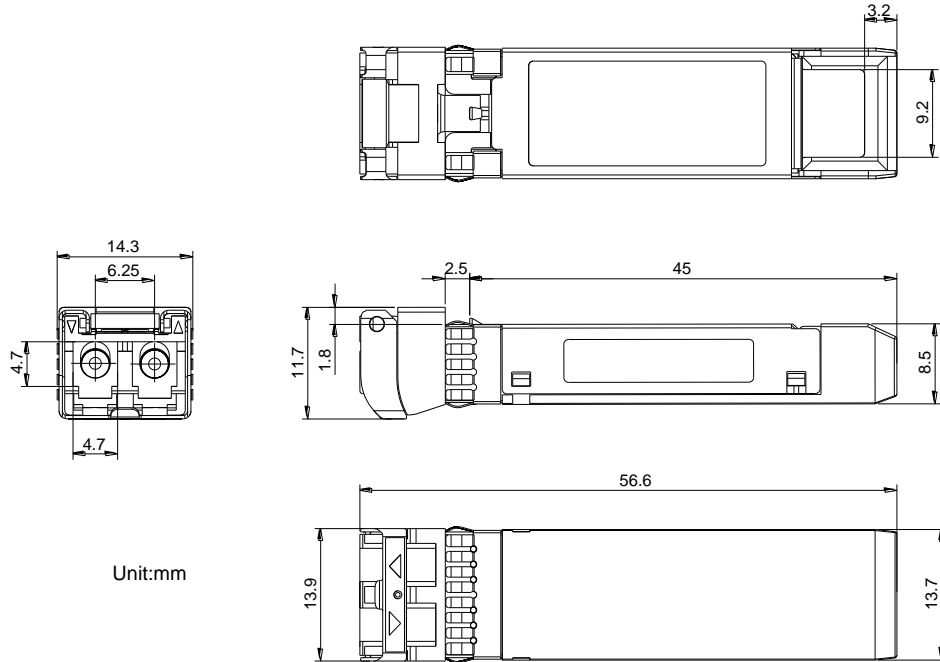

Figure4. Mechanical Specifications

Shenzhen Sourcelight Technology Co., Ltd

Sourcelight Technology reserves the right to make changes to or discontinue any optical link product or service identified in this document without notice in order to improve design and/or performance. If you have any question regarding this specification sheet, please contact our sales representative or send email to sales@sourcelight.com.cn