

25G SFP28 850nm 100m SR

SLSS-2585-SR



Overview

SLSS-2585-SR 25G SFP28 transceivers, This 850 nm VCSEL 25Gigabit SFP28 transceiver is designed to transmit and receive optical data over 50 μ m multimode optical fiber OM3 70m and OM4 100m.

The SFP28 SR module electrical interface is compliant to SFI electrical specifications. The transmitter input and receiver output impedance is 100 Ohms differential. Data lines are internally AC coupled. The module provides differential termination and reduce differential to common mode conversion for quality signal termination and low EMI. SFI typically operates over 200 mm of improved FR4 material or up to about 150mm of standard FR4 with one connector.

Ordering Information

Part Number	Product Description
SLSS-2585-SR	SFP28 25Gbps, 850nm, OM4 MMF 100m, 0°C ~ +70°C

Features

- ◆ 25Gb/s serial optical interface
- ◆ 850nm VCSEL transmitter, PIN photo-detector
- ◆ 2-wire interface for management specifications compliant with SFF 8472 digital diagnostic monitoring interface for optical transceivers
- ◆ Operating case temperature: 0 to 70°C
- ◆ All-metal housing for superior EMI performance
- ◆ Low power consumption
- ◆ Advanced firmware allow customer system encryption information to be stored in transceiver
- ◆ Cost effective SFP28 solution, enables higher port densities and greater bandwidth
- ◆ RoHS compliant

Applications

- ◆ High-speed storage area networks
- ◆ Computer cluster cross-connect
- ◆ Custom high-speed data pipes
- ◆ Inter Rack Connection

Absolute maximum rating

Parameters	Symbol	Min.	Max.	Unit
Power Supply Voltage	VCC	0	3.6	V
Storage Temperature	Tc	-40	85	°C
Operating Case Temperature	Tc	0	70	°C
Relative Humidity	RH	5	95	%

Recommended Operating Condition

Parameter	Symbol	Min.	Typical	Max	Unit
Power Supply Voltage	VCC	3.135	3.3	3.465	V
Power Supply Current	Icc			300	mA
Operating Case Temperature	TC	0	25	70	°C

Transceiver Optical Characteristics

Parameter	Symbol	Minimum	Typical	Maximum	Unit	Notes
Transmitter						
Center Wavelength	λ_t	840	850	860	nm	
RMS spectral width	Pm			0.6	nm	
Average Optical Power	Pavg	-8.4		2.4	dBm	
Optical Power OMA	Poma	-6.4	-1.5	3	dBm	
Laser Off Power	Poff			-30	dBm	
Extinction Ratio	ER	2			dB	
Transmitter Dispersion Penalty	TDP			4.3	dB	
Optical Return Loss Tolerance				12	dB	
Receiver						
Center Wavelength	λ_r	840	850	860	nm	
Receiver Sensitivity (Average power)	Psens		-9.5		dBm	BER = 1x10 ⁻¹²
Receiver Sensitivity (OMA)	Psens			-10.3	dBm	BER <5x10 ⁻⁵
Stressed Sensitivity (OMA)				-5.2	dBm	BER <5x10 ⁻⁵
LOSAssert	LOSA	-30			dBm	
LOSDeassert	LOSD			-12	dBm	
LOS Hysteresis	LOSH				dB	
Overload	Pin	2.4			dBm	Note1
Receiver Reflectance				-12	dB	

Notes:

- Note1: Typical BER is less than 1x10⁻¹², maximum BER is 5x10⁻⁵.

Transmitter Electrical Characteristics

Parameter	Symbol	Minimum	Typical	Maximum	Unit	Notes
Data Rate		-	25.78	-	Gbps	
Power Consumption		-	900	1000	mW	
Single Ended Input Voltage Tolerance		-0.3		4	V	
AC Common mode voltage tolerance		15			mV	RMS
Differential Input Voltage Swing	Vin	180		700	mV	
Differential Input Impedance	Zin	90	100	110	Ohm	

Receiver Electrical Characteristics

Parameter	Symbol	Minimum	Typical	Maximum	Unit	Notes
Single-ended Output Voltage		-0.3	-	4	V	
Differential Output Voltage Swing	Vo	300		850	mV	
AC Common Mode Output Voltage				7.5	mV	RMS
Differential Output Impedance	Zout	90	100	110	Ohm	

Pin Definition

Pin	Symbol	Name/Description	Note
1	VEET	Transmitter Ground	1
2	TX_Fault	Transmitter Fault (LVTTTL-O) - High indicates a fault condition	
3	TX_Disable	Transmitter Disable (LVTTTL-I) – High or open disables the transmitter	
4	SDA	Two wire serial interface Data Line (LVCMOS-I/O) (MOD-DEF2)	2
5	SCL	Two wire serial interface Clock Line (LVCMOS-I/O) (MOD-DEF1)	2
6	MOD_ABS	Module Absent (Output), connected to VeeT or VeeR in the module	
7	RS0	Rate Select 0 – Not used, Presents high input impedance	
8	RX_LOS	Receiver Loss of Signal (LVTTTL-O)	
9	RS1	Rate Select 1 – Not used, Presents high input impedance	
10	VeeR	Receiver Ground	1
11	VeeR	Receiver Ground	1
12	RD-	Inverse Received Data out (CML-O), AC Coupled	
13	RD+	Received Data out (CML-O), AC Coupled	
14	VeeR	Receiver Ground	1
15	VccR	Receiver Power - +3.3V	
16	VccT	Transmitter Power - +3.3 V	
17	VEET	Transmitter Ground	1

Datasheet

18	TD+	Transmitter Data In (CML-I), AC Coupled	
19	TD-	Inverse Transmitter Data In (CML-I), AC Coupled	
20	VEET	Transmitter Ground	1

Notes:

1. Module ground pins GND are isolated from the module case.
2. Shall be pulled up with 4.7K-10Kohms to a voltage between 3.15V and 3.45V on the host board.

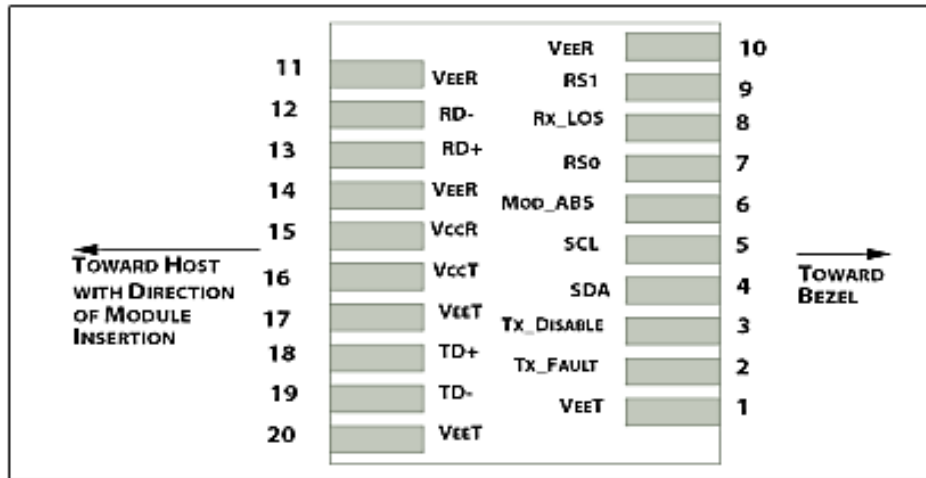

Figure 1: Interface to Host PCB

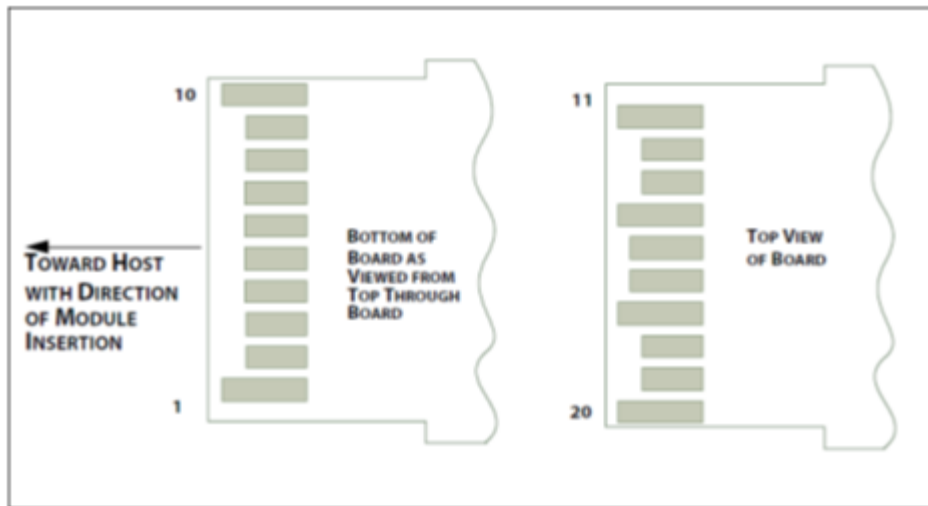

Figure 2: Module Contact Assignment

Transceiver Block Diagram

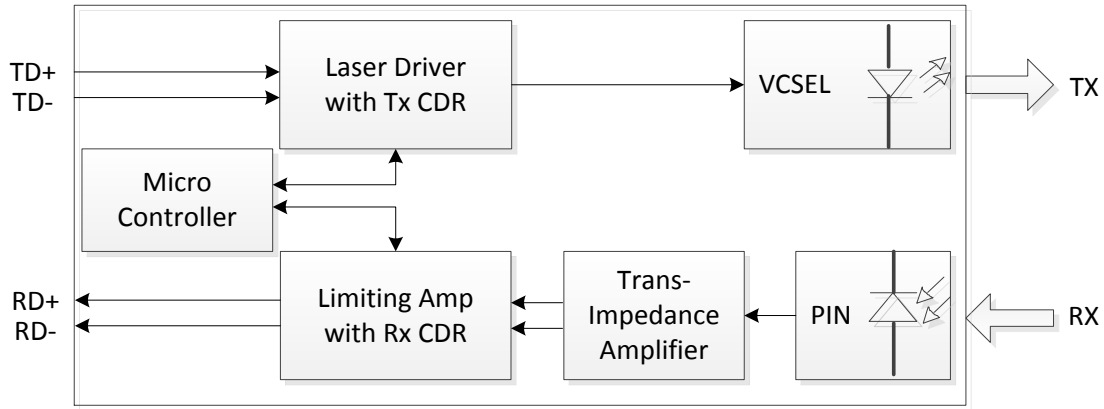

Figure 3: Transceiver Block Diagram

Mechanical Specifications

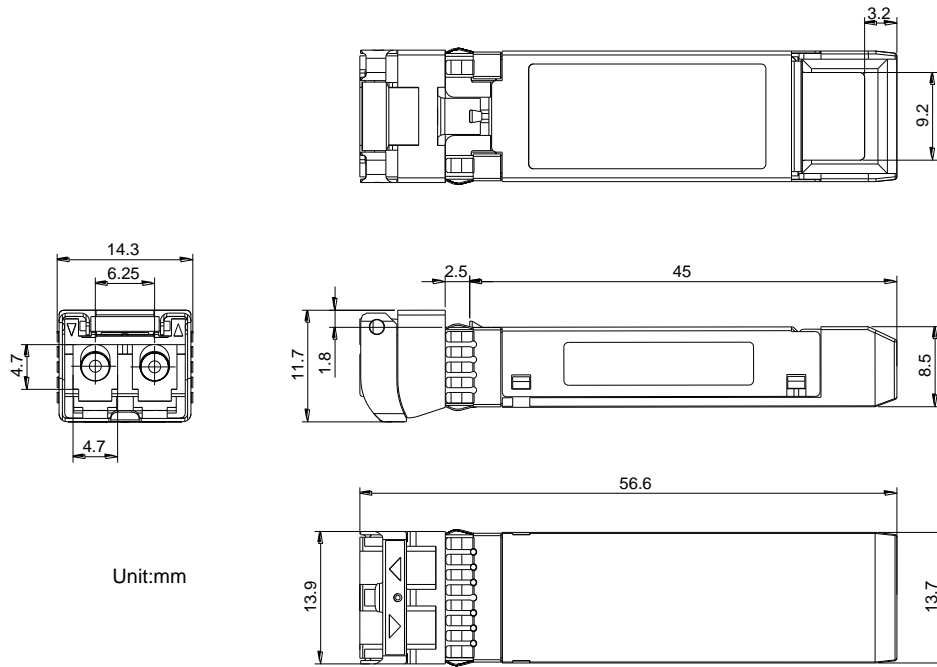

Figure4. Mechanical Specifications

Shenzhen Sourcelight Technology Co., Ltd

Sourcelight Technology reserves the right to make changes to or discontinue any optical link product or service identified in this document without notice in order to improve design and/or performance. If you have any question regarding this specification sheet, please contact our sales representative or send email to sales@sourcelight.com.cn